

DETAIL Y3

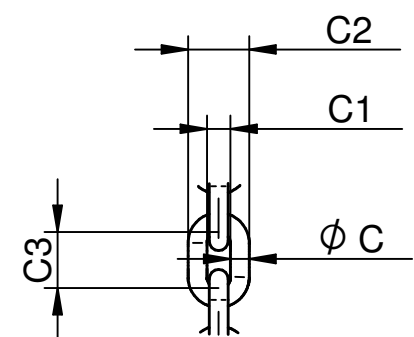

DETAIL Y2

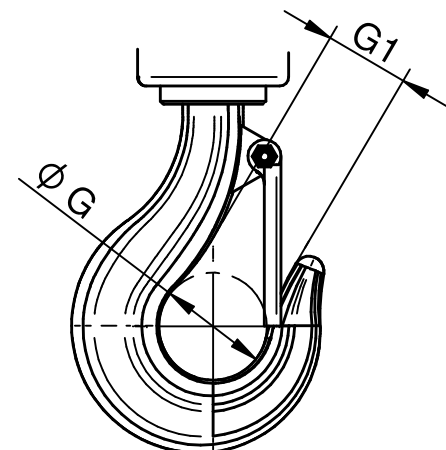

DETAIL Y1

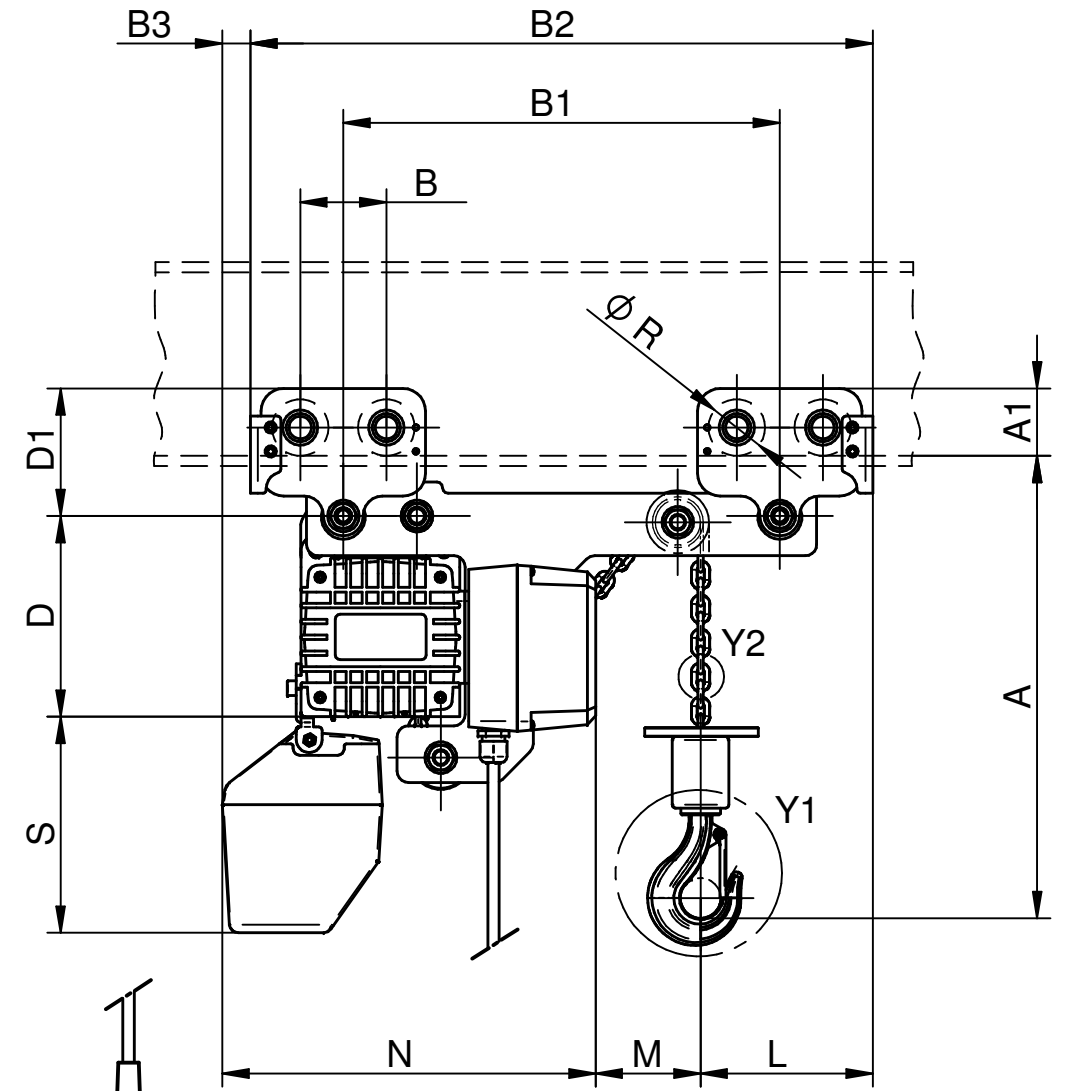

Model	Capacity [Kg]	Speed [m/min.]	Kw	Chain Falls	A	A1	B	B1	B2	B3	ϕC	C1	C2	C3	D	D1	E	F	ϕG	G1	H	H1	H2	H3	L	M	N	ϕR	S	ϕT	Weight [Kg]
500W4	500	4	0,8	1	255	60	76	385	550	25	5	6	16,9	15	177	113	18	16	37	26	150	235	205	440	150	100	325	50	225	14	47
500W6	500	6	0,8	1	255	60	76	385	550	25	5	6	16,9	15	177	113	18	16	37	26	150	235	205	440	150	100	325	50	225	14	47
500W8	500	8	1	1	255	60	76	385	550	25	5	6	16,9	15	177	113	18	16	37	26	150	235	205	440	150	100	325	50	225	14	53
500W12	500	12	1,5	1	255	60	76	385	550	25	5	6	16,9	15	177	113	18	16	37	26	150	245	225	470	150	100	325	50	225	14	53
500W14	500	1-4	0,25-1	1	255	60	76	385	550	25	5	6	16,9	15	177	113	18	16	37	26	150	245	225	470	150	90	335	50	225	14	53
500W28	500	2-8	0,4-1,8	1	295	87	98	420	645	\	7	8,4	23,6	22	205	150	27	25	37	26	190	250	233	483	170	133	342	65	280	18	78