

DETAIL Y4

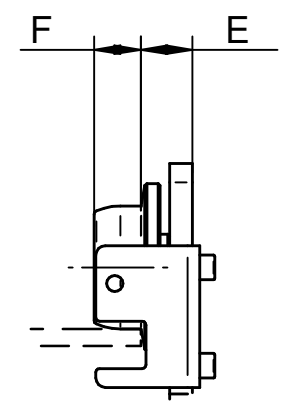

DETAIL Y3

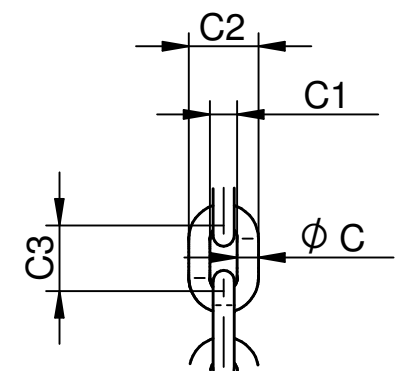

DETAIL Y2

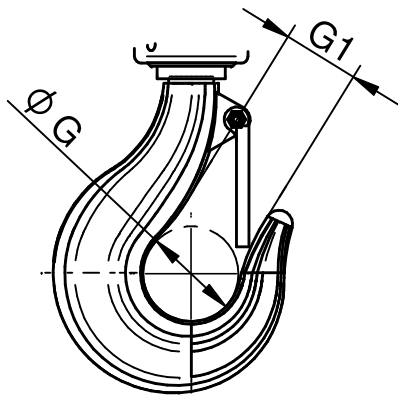

DETAIL Y1

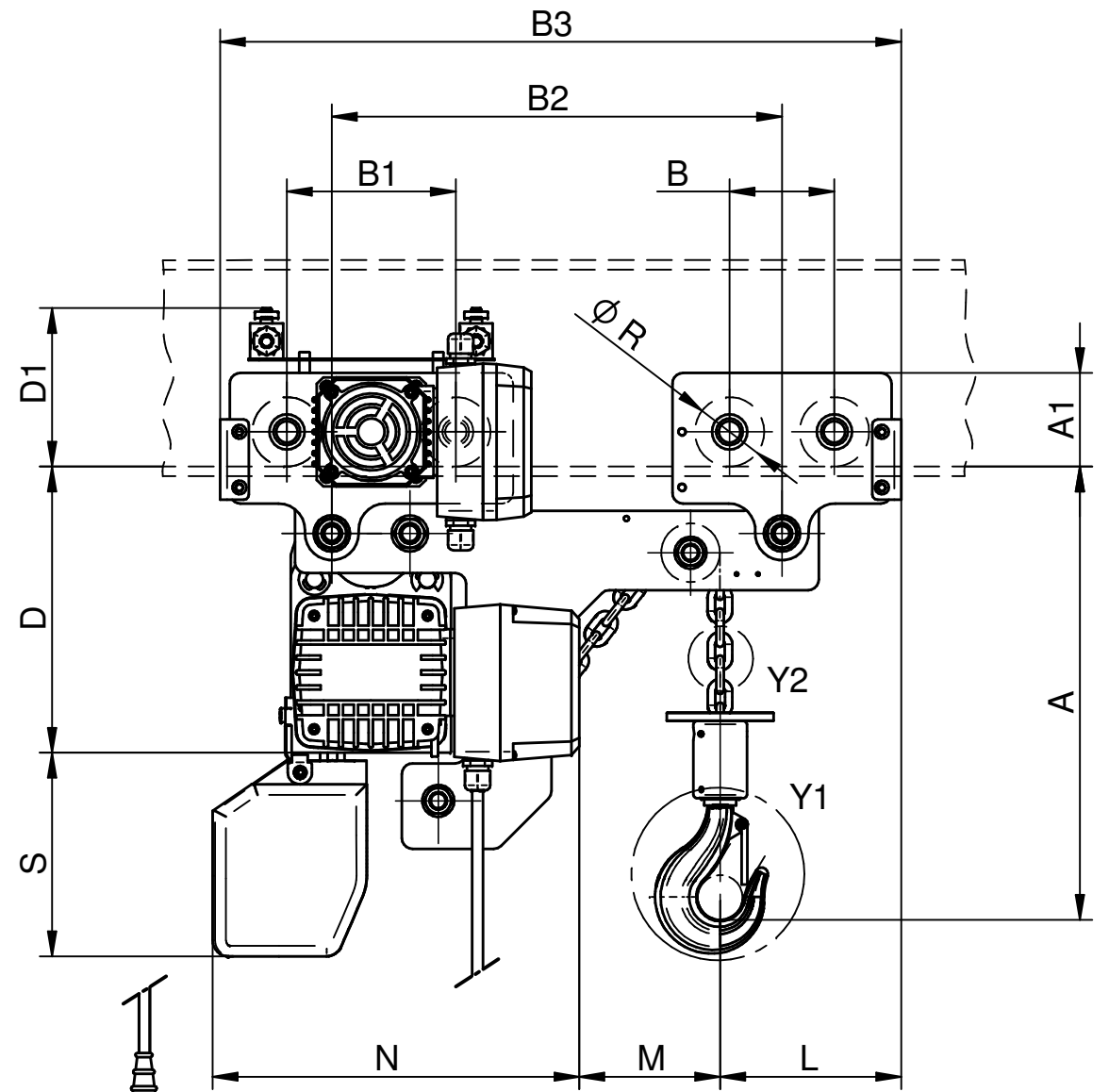

Model	Capacity [Kg]	Speed [m/min.]	Kw	Chain Falls	A	A1	B	B1	B2	B3	Ø C	C1	C2	C3	D	D1	E	E1	F	Ø G	G1	H	H1	H2	H3	L	M	N	Ø R	S	Ø T	Weight [Kg]
1000W4	1000	4	1	1	310	87	98	158	420	637	7	8,4	23,6	22	270	145	27	31	25	43	32	190	250	233	483	170	133	342	65	280	18	88
1000W6	1000	6	1,6	1	310	87	98	158	420	637	7	8,4	23,6	22	270	145	27	31	25	43	32	190	250	233	483	170	133	342	65	280	18	90
1000W14	1000	1-4	0,4-1,8	1	310	87	98	158	420	637	7	8,4	23,6	22	270	145	27	31	25	43	32	190	270	233	503	170	133	342	65	280	18	90